

DIVERSIFIED AIR SYSTEMS, INC.

# MAXDROP™

*Hose drop for fume and gases  
exhaust systems*



- *Easy to use and install*
- *Small cars to diesel trucks application*
- *Spring balancer with ratchet lock system*
- *Multiple hose diameter and temperature options*

*Superior technology generating substantial operating savings*

# MAXDROP™

*High-Productivity Innovative Products*

## **MAXDROP** *Hose drop for fume and gases exhaust systems*

The MAXDROP hose drop system is an interesting alternative to hose reels. Designed to work with small cars right up to big diesel engines, MAXDROP assures that the hoses will not be crushed by workers or vehicles since they are lifted and secured by the balancer. The ratchet lock system on the balancer allows the hose to be pulled at the exact length required. Single, dual or fan equipped systems are also offered with different diameters, lengths and temperature ratings of hoses. A variety of tailpipe adaptors is also offered depending on the application.

## *Industrial Air Specialists*

With our headquarters in Louisville, Kentucky, Diversified Air Systems, Inc. has been providing quality air solutions to industrial and commercial facilities since 1981. During our more than twenty-nine years of operation, Diversified Air Systems, Inc. has established two important company traditions: offering state-of-the-art equipment at competitive prices and achieving long-term customer satisfaction.

The staff of Diversified Air Systems, Inc. includes five application engineers, with a combined experience of more than 75 years in the air filtration and HVAC industry. Whether your facility requires an air filtration system for dust, mist, or fumes, or an HVAC solution to meet ventilation needs, Diversified Air Systems, Inc. has the equipment and expertise to meet the need.

Services include air quality analysis, system design, equipment sales, turnkey installation, onsite servicing, and supply of replacement filters and accessories.

### **Other Filtration Systems available:**

Air Cleaners

Containment Booths

Decontamination Booths

Downdraft Tables

Dust Collectors

Fans and Blowers

Gas & Odor Control

High Vacuum Systems

Mist Collectors

Paint Booths

Stainless Steel Collectors

Vehicle Exhaust Systems

Wet Dust Collectors



## MAXDROP VERSATILITY FOR MULTIPLE APPLICATION

*Suitable for any application from ATV repair facilities right up to large truck maintenance shops*

*Most of our competitors do not include these standard features:*

- Balancer ensures the flexible hose does not rest on floor and risks of being crushed
- Available with direct mount fan
- Can also be used for removing harsh fumes in tanks or containers
- Hoses available in different diameters, temperature ratings and lengths
- Wide variety of tailpipe adaptors
- Full kit for easy installation

## TYPICAL MAXDROP ARRANGEMENTS



## OUTSTANDING MAXDROP FEATURES



CHART 1

Vehicle type	Recommended air volume CFM/L/s	Recommended hose diameter [inches] / [mm]	Recommended hose temperature [°F] / [°C]
Small to full size cars	250-300/ 115-140	3-4/75-100	200-300/ 120-150
Performance sports cars	450-500/ 210-235	4-5/100-125	500-600/ 260-325
Large pick-up trucks/SUV's	350-400/165-190	4-5/100-125	500-600/ 260-325
Diesel trucks/ tractor trailers	700-800/330-375	6/150	500-600/ 260-325
Heavy duty off road machinery	1000-1200/470-565	8/200	900-1200/ 480-650

Some engines may exhaust fumes at higher temperatures than 900°F (480°C). Consult with engine or vehicle manufacturer's specifications.

Note on flexible hoses : fumes vacuumed into flexible hoses are cooled with drawn ambient air. Combination of extreme, high and low temperature hoses are available in order to minimize operating costs. Call factory or representative for details.

## MAXDROP TYPICAL INSTALLATIONS

Ceiling trusses installation with braided rope, pulleys and wall cleats



Ceiling trusses installation with spring balancer but without support bracket



Typical wall / post installation with support bracket (without fan)



Typical wall / post installation with support bracket and fan



## MAXDROP EQUIPMENT FOR TYPICAL INSTALLATIONS

- 1 : two (2) 8" wall cleats, one (1) hose sling, two (2) 3" pulleys, two (2) hose clamps, one (1) 1/4" X 100' braided rope with thimbles, one (1) tangle free turnbuckle.
- 2 : one (1) spring balancer with 15' travel cable and ratchet lock, one (1) 1" X 15' chain with eyebolt and nut, one (1) hose sling, two (2) hose clamps, one (1) tangle free turnbuckle.
- 3 : one (1) equipment support bracket, one (1) or two (2) spring balancer(s) with 15' travel cable and ratchet lock, one (1) or two (2) hose sling(s), two (2) or four (4) hose clamps, one (1) or two (2) tangle free turnbuckle(s).
- 4 : one (1) exhaust fan (not included, to be selected with MAXDRIVE leaflet), one (1) equipment support bracket, one (1) or two (2) spring balancer(s) with 15' travel cable and ratchet lock, one (1) or two (2) hose sling(s), two (2) or four (4) hose clamps, one (1) or two (2) tangle free turnbuckle(s).

### Tailpipe adaptors

Because of the wide variety of shapes and sizes on cars and trucks tailpipes, adaptors are not included in the typical installations described above. Page 7 of this leaflet includes a complete list of available tailpipe adaptors and nozzles to be fitted with the MAXDROP hose drop systems.

## MAXDRIVE FANS (3450 R.P.M.)

Backward inclined (recommended for 6" and 8" diameter drops [150mm and 200mm])

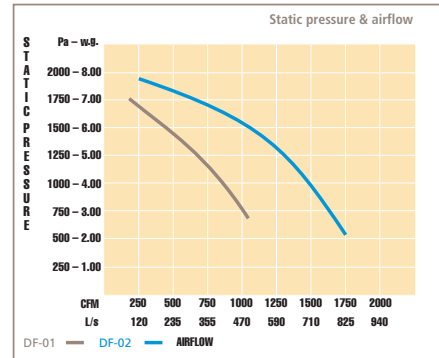
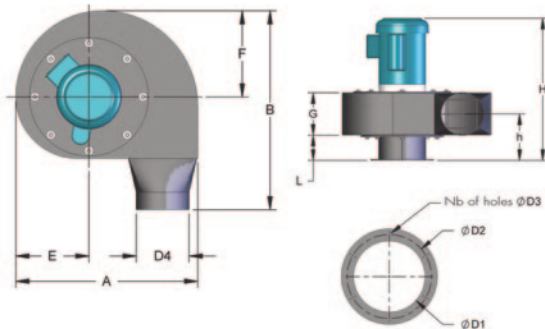

### Dimensions

CHART 2

Model	Power [HP]	Dimensions [inches] / [mm]											Weight [lbs] / [kg]		
		A	B	E	F	H	L	G	h	d1	d2	d3		d4	n
DF-01	1 / 0.75	20.2 / 513	22.6 / 574	8.3 / 211	9.8 / 249	21.1 / 536	3.9 / 99	5.9 / 150	6.9 / 175	6.25 / 160	7.69 / 195	0.4 / 9	6 / 198	6	70 / 31.8
DF-02	2 / 1.50	22.7 / 577	24.8 / 630	9.2 / 234	11 / 279	24.8 / 630	4.9 / 124	6.3 / 160	7.4 / 188	8 / 200	9.69 / 246	0.4 / 9	8 / 249	8	82 / 37.3

Electrical note: Motors are available in all voltages. Specify on order.

Radial blade (recommended for 3", 4" and 5" diameter drops [75mm, 100mm and 125mm])

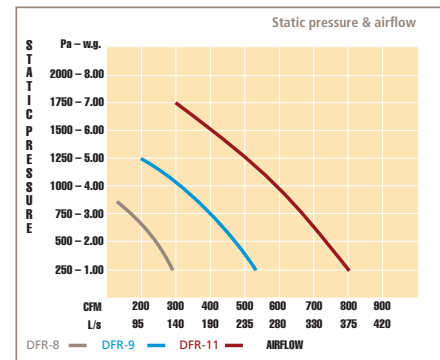
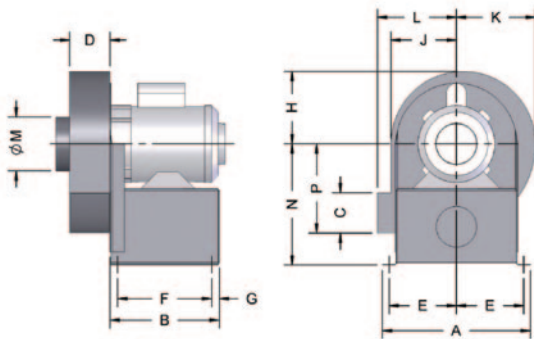

### Fan dimensions

CHART 3

Model	[HP] / [KW]	Dimensions [inches] / [mm]													Weight [lbs] / [kg]	
		A	B	C	D	E	F	G	H	J	K	L	M	N		P
DFR-8	0.33 / 0.25	11 / 279	8 / 203	8 / 203	3 / 76	5 / 127	7 / 178	0.5 / 13	5.38 / 137	4.88 / 124	5.88 / 149	5.88 / 149	4 / 102	6.63 / 168	9 / 229	44 / 20
DFR-9	0.33 / 0.25	12.13 / 308	8 / 203	3.5 / 89	3.5 / 89	5.63 / 143	7 / 178	0.5 / 13	6.38 / 162	5.75 / 146	6.88 / 175	6.75 / 171	5 / 127	7.5 / 191	9.88 / 251	46 / 21
DFR-11	1 / 0.75	14.75 / 375	9 / 229	4 / 102	3.5 / 89	6.88 / 175	7.5 / 191	0.75 / 19	7.25 / 184	6.5 / 165	8 / 203	7.63 / 194	6 / 152	8.63 / 219	11.75 / 298	62 / 28

Electrical note: motors are available in 115/1160 only.

## TAILPIPE ADAPTORS & NOZZLES

Rubber adaptors  
protect chrome tailpipes

### NZR-TPA3000



Y adaptors designed for split tailpipes up to 3" (75 mm) in diameter. Y hoses 24" long each. (crush-resistant)  
Note: to be used temporarily. Not to be permanently attached to hose reel.

### NZR-YA300-400



Y adaptors designed for split tailpipes 3" (75 mm) or 4" (100 mm) in diameter. Y hoses 48" long each. (crush-resistant)  
Note: to be used temporarily. Not to be permanently attached to hose reel.

### NZR-F300-350-400



Straight adaptors with hook and chain. Up to 2,5" (65 mm), 3" (75 mm) or 3,5" (90 mm) in diameter. (crush-resistant)

### NZR-F475-575



3" x 6" (75 x 150 mm) or 3" x 8" (75 x 200 mm) oval shaped for dual tailpipes. Attached to tailpipe by means of hook and chain. (crush-resistant)

### NZR-TWINFLAP



4" x 9" (100 mm x 225 mm) for side by side tailpipes rubber nozzle equipped with slotted closing flaps minimizing air loss. (crush-resistant)

### NZR-RA300



Fits most car and light truck tailpipe sizes up to 3" (75 mm). Attached to tailpipe by means of cuffs and slots. (crush-resistant)

Galvanized or stainless steel tailpipe adaptors  
(also available in stainless steel, contact factory for details)

### NZA-DC-06-08

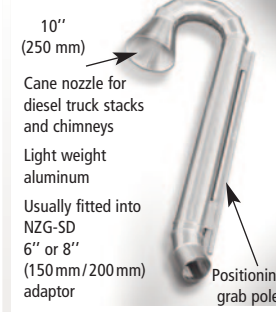

10" (250 mm)  
Cane nozzle for diesel truck stacks and chimneys  
Light weight aluminum  
Usually fitted into NZG-SD 6" or 8" (150 mm / 200 mm) adaptor  
Positioning grab pole  
Note: cane nozzle is to be used temporarily. Not to be permanently attached to hose reel.

### NZ-POLE-SQ-HO



Telescopic aluminium pole (8' to 16') with grab hook. Recommended when hose and nozzle are fully wrapped around the drum and is out of arm's reach. Nozzle below is fitted with 2" eyebolt for grab hook and pole insert  
NZG-OE-HO

### NZG-SD



Spring loaded damper type. Available from 4" to 8" (100 to 200 mm).

### NZG-SLEA



Spring loaded damper type with port emission analyzer. Available from 4" to 8" (100 to 200 mm).

### NZG-VG



Available with or without spring loaded damper type with vise-grip attachment. Available from 4" to 8" (100 to 200 mm). Required for high RPM testing facilities.

### NZG-OE

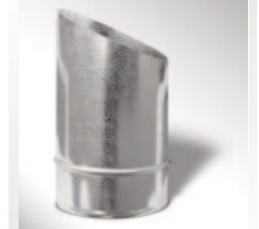

Open nozzle adaptor. No tailpipe attachment included. Available from 4" to 8" (100 to 200 mm).

Optional rag stop 1/2" x 1/2" wire mesh: stainless steel HW-WMSS1/2 or galvanized steel HW-WM1/2

Note on opened end type nozzles : continuous exhaust through opened end type nozzle will use air flow uselessly when hose drop is not in use. For maximum exhaust performance, select optional spring loaded damper tailpipe adaptors if possible.

## FLEXIBLE HOSES

CHART 4

Model	Maximum temperature	Fabric [inches] / [mm]	Usage / Application	Diameters
HO-240H-X	240-300°F / 115-135°C	Cotton neoprene with exterior helix	Cars-light trucks	3 to 8" (75 to 200 mm)
HO-500-X	-500-600°F / 260-315°C	Two (2) ply silicone fiber	High revolution engines, diesel trucks	3 to 8" (75 to 200 mm)
HO-500W-X	-500-600°F / 260-315°C	Two (2) ply silicone fiber with protective wearstrip	High revolution engines, diesel trucks	3 to 8" (75 to 200 mm)
HO-900H-X	900-1000°F / 480-535°C	E-glass polyurethane with exterior helix	Quarry and heavy duty machinery	3 to 8" (75 to 200 mm)
HO-1200H-X	1200-1350°F / 650-730°C	2 ply E-glass polyurethane with exterior helix	Extreme temperature	3 to 8" (75 to 200 mm)

HO-240H-X



HO-900H-X



HO-500-X



HO-1200H-X

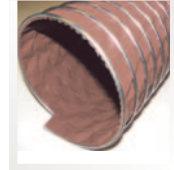

\*Available with protective wearstrip

DAS will not be held liable if flexible hose selected is used for higher exhaust temperatures than the tolerance indicated in the chart 7.  
Note : X digit at end of model number indicates hose diameter. Ex : HO-500-6 equals to a 6" diameter hose. Specify length required.  
Crush resistant hose available for specific applications only. Contact factory for details

## MAXDROP MODEL NUMBERING SYSTEM (HD letters stand for Hose Drop)

Step 1: Select hose lifting device. Ex: rope/pulley = HDSP

Step 4: Select hose temperature tolerance. Ex : 2 = 240 °F

Step 2: Select hose diameter. Ex: 5 = 5"

Step 5: If bracket is needed to support components, add:

Step 3: Select hose length. Ex: 25 = 25'

Ex 1 : SB = support bracket for equipment only

Ex 2 : SBF = support bracket for equipment and fan

## SEQUENCE IN MODEL NUMBERING SYSTEM

### 1. CODES FOR LIFTING DEVICE

• **HDSP = Hose Drop Single** with Pulleys

• **HDSB = Hose Drop Single** with Balancer

• **HDDB = Hose Drop Double** with Balancer

### 2. CODES FOR HOSE DIAMETER (SHOWN IN INCHES)

• 3 = 3    4 = 4    5 = 5    6 = 6    8 = 8

### 3. CODES FOR HOSE LENGTH (SHOWN IN FEET)

• 16 = 16                      25 = 25

### 4. CODES FOR HOSE TEMPERATURE TOLERANCE (SHOWN IN °F)

• 2 = 240            5 = 500            9 = 900            1 = 1200

### EXAMPLE FOR COMPLETE HOSE DROP MODEL NUMBERING SYSTEM

• Ex 1: HDSB - 6165: Hose Drop Single Balancer with 6" diameter hose, 16' long, 500 °F hose temperature tolerance

• Ex 2: HDDB - 4252SB : Hose Drop Double Balancer with two (2) 4" diameter hoses, 25' long, 240 °F hose temperature tolerance, support Bracket

## CREATE YOUR MAXDROP HOSE DROP SPECIFICATION

### 1. HOSE DROP SHOULD INCLUDE :

flexible hose support sling with tangle free turnbuckle, hose clamps

### 2. HOSE DROP SHOULD INCLUDE LIFTING DEVICE BY MEANS OF :

A) rope and pulleys  B) single balancer   
C) double balancer

### 3. HOSE DIAMETER SHOULD BE :

A) 3"  B) 4"  C) 5"  D) 6"  E) 8"

### 4. HOSE LENGTH SHOULD BE :

A) 16'  B) 25'

### 5. HOSE MODEL SHOULD BE :

A) HO-240H-X  B) HO-500-X  C) HO-500W-X   
D) HO-900H-X  E) HO-1200H-X

### 6. HOSE DROP SHOULD INCLUDE :

A) support bracket for hose drop only   
B) support bracket for hose drop with exhaust fan

### 7. HOSE DROP SHOULD INCLUDE FAN MODEL :

refer to recommended fan selection in this leaflet (page 6)

### 8. HOSE DROP SHOULD INCLUDE TAILPIPE ADAPTOR MODEL :

selection to be made from list of available adaptors in this leaflet (page 7)

### 9. HOSE DROP SHOULD INCLUDE :

balancer mounted micro-switch for automatic fan start/stop (starter and transformer not included).

*Note: specifications listed above may be modified to suit application. Contact DAS or representative for information.*

### Diversified Air Systems, Inc.

10801 Electron Drive, Louisville, Kentucky 40299

Toll free: **(800) 264-8958**

Tel.: **(502) 267-0333** • Fax: **(502) 267-4241**

Website: [www.diversair.com](http://www.diversair.com) • email: [info@diversair.com](mailto:info@diversair.com)