

WETREX™ SERIES



WET DUST COLLECTION TECHNOLOGIES



PROVEN TECHNOLOGY	1
FILTRATION EFFICIENCY	3
ACCESSORIES	5
WATER TREATMENT	7
SAFE WORKING ENVIRONMENT	9
WET DOWNDRAFT TABLE	11
WET BOOTH	13
SPECIFICATIONS	15

LET US WORRY ABOUT THE DETAILS WHILE YOU THINK ABOUT THE REST !

We are working on creating the next generation of wet collectors.

Our experienced team of engineers have created a unit that is unsurpassed in quality and offers the highest efficiency rates in the industry.

The unique core and polypropylene impinger puts us way ahead of our competitors for maintenance and ease of operation.

Because our controls are simple and state-of-the-art, using our system is a breeze.

ADVANTAGES

Eliminates sparks and fire risk
Deflectors force sparks into submerged water bath;

Regulations
Meets OSHA and NFPA regulations;

Mist eliminator
Is supplied with washable filters;

Energy savings
Recirculates air (saves heat and cooling) by re-using filtered air volume instead of evacuating polluted air;

Controls
Plug and play simple systems which are pre-wired and pre-tested in our factory.

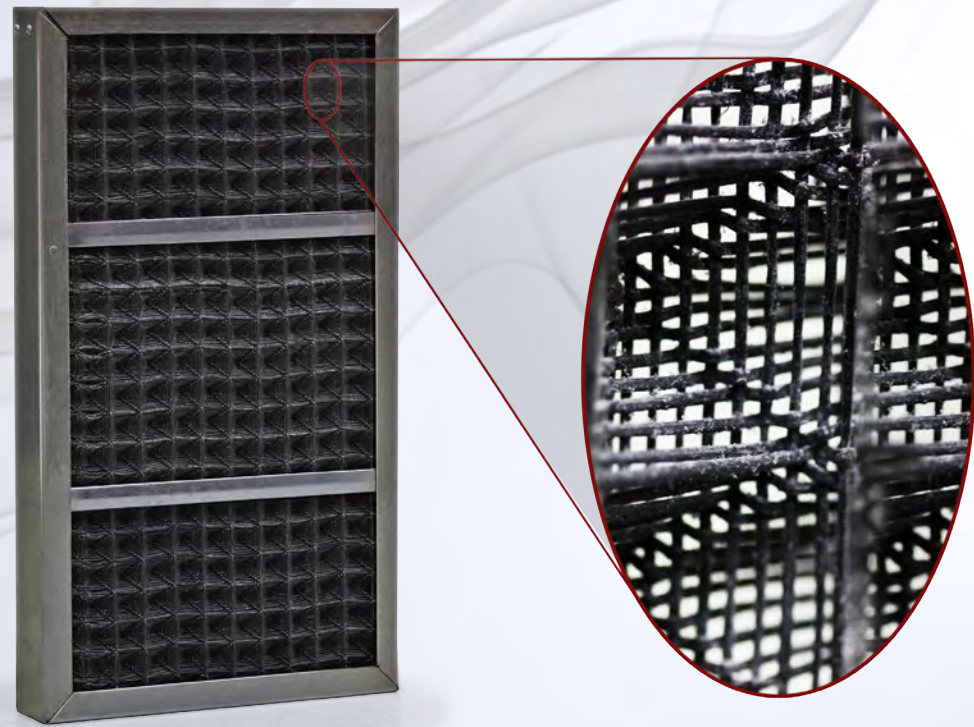
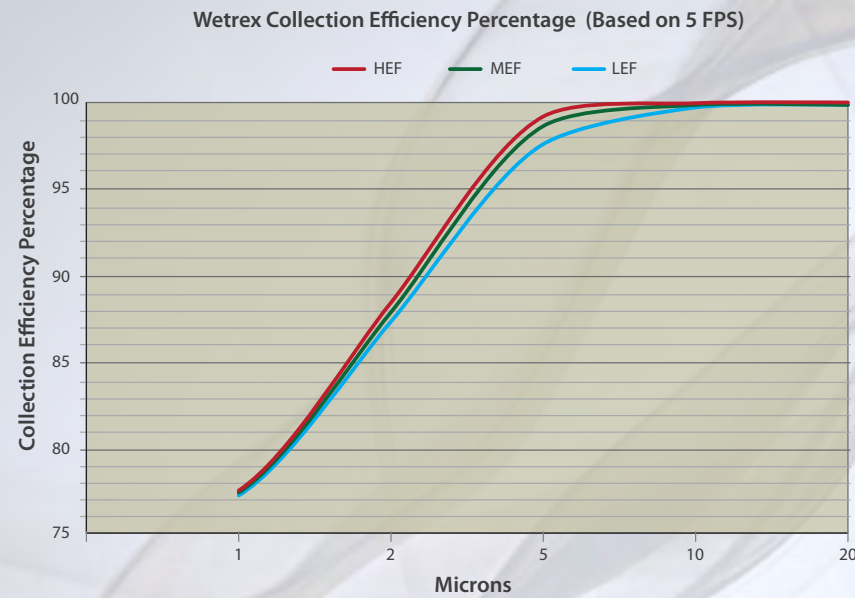

Magnified view of the mist eliminator filter

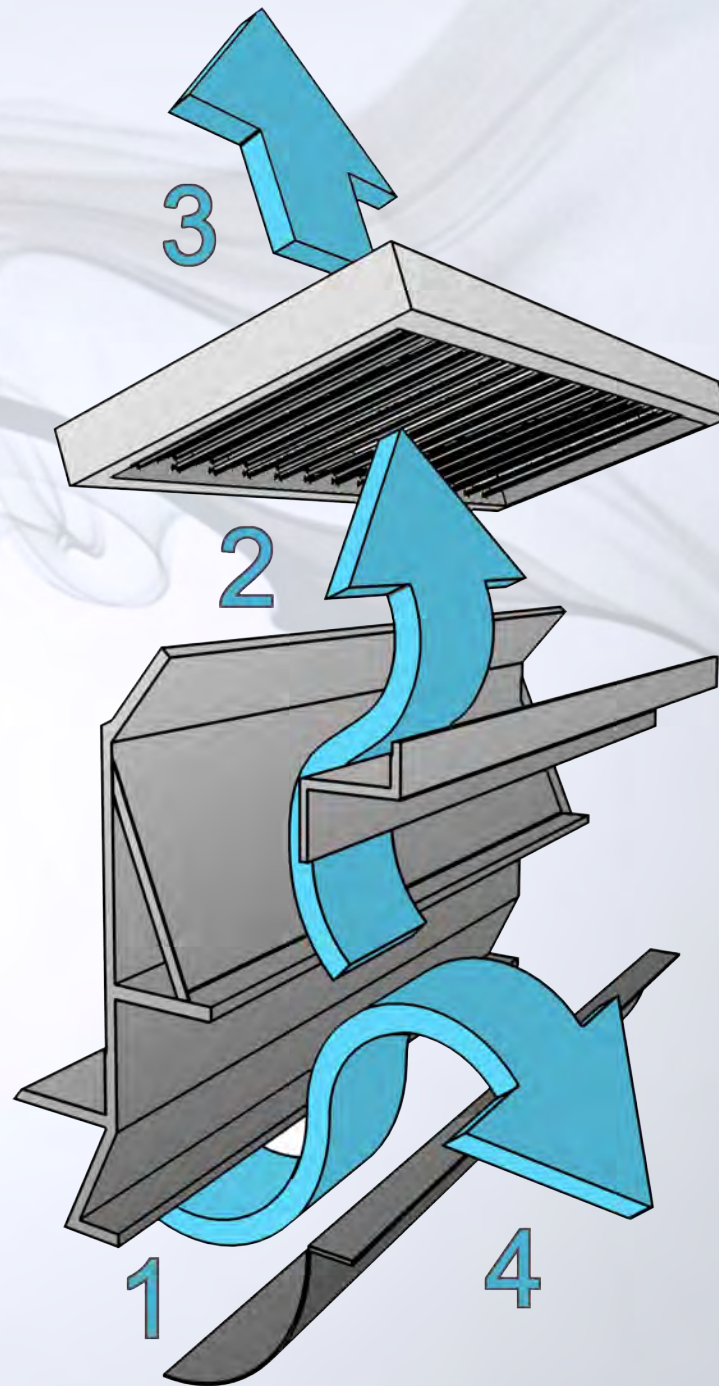

Inside the Wetrex™;
baffles, impellers & filters

FILTRATION EFFICIENCY

3

EFFICIENCY EXCEEDING ALL EXPECTATIONS

1. In order to achieve particle immersion, a turbulent water zone forces the particles into the water. The main baffle then ensures the particles are submerged and redirected to the basin.
2. The air and water mixture is then forced through another series of baffles that help separate the clean air from the dirty water.
3. Secondary mist eliminators drain out any water remaining in the air stream.
4. The water returns to the storage bin where gravity forces the particles to settle. It is then reused during the sludge and debris removal stage.

MIST ELIMINATOR

The core filter system incorporates different pad mesh mixes which optimize particle filtration.

Our unique impinger allows us to generate the optimal filtration efficiency for your particular application.

Advantages;

- Easy cleaning
- Multilayered
- Interchangeable
- Corrosive resistant
- Light weight
- Low pressure drop



ACCESSORIES

5

WHAT IS OPTIONAL TO SOME IS ESSENTIAL TO US

Our units include the following standards:

Airtight Bassin Access Door

The sealed top access allows the Wetrex to operate under pressures of up to 16" H₂O when other wet dust collectors are limited to 6" H₂O.

Door Seal with full Gasket

Door sealing is made easier and seal life is extended.

Sensor

Controlled ultrasonic sensor for water level monitoring and replacement of water evaporated by the process.

Overflow nipple

Allows water to drain in case of high water levels.

High / Low level alarm

Water control with sensor to ensure basin is at optimal water level. Sensor protects a critical bypass failure or an overflow situation.

OPTIONAL FEATURES

Spray-Wash System

In environments where the filter can clog (e.g. in paper or textile industries), the addition of a spray nozzle system will reduce the need for filter cleaning if operation cannot be disrupted.

Hydrocyclone

Removal of sludge using a pump and cyclone technology.

Hydrogen Power Vent

Independent blower to eliminate hydrogen gas build-up during down (off) time.

How the Hydrocyclone Filtration System Works

1. A centrifugal pump pushes contaminated water containing particles through a filtration circuit.
2. A hydrocyclone separates 90% of the solid particles over 40 microns from the water using centrifugal force. Solids are then evacuated to a sedimentation tank.
3. Thanks to an automated valve, the sedimentation tank is periodically drained to a waste water tank that recovers a large amount of mud.
4. A distribution manifold returns water to the Wetrex™ to prevent accumulation of solids at the bottom.
5. The addition of a valve network allows the system to bypass the filter during component replacement and maintenance.

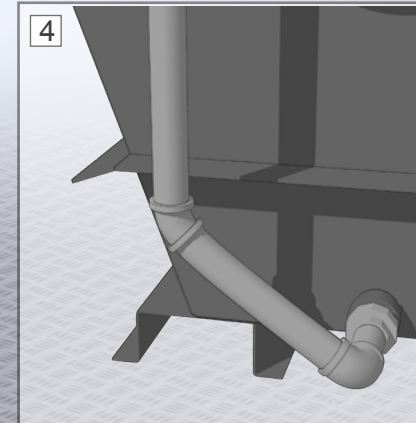
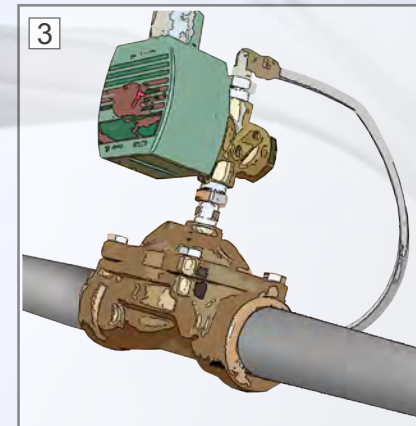
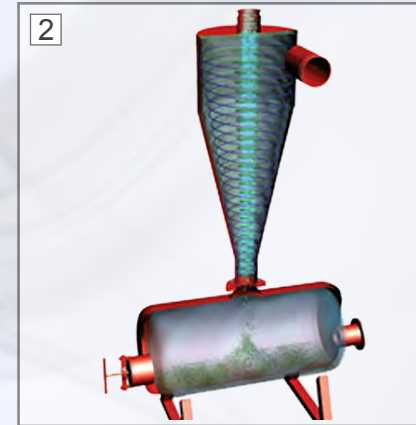
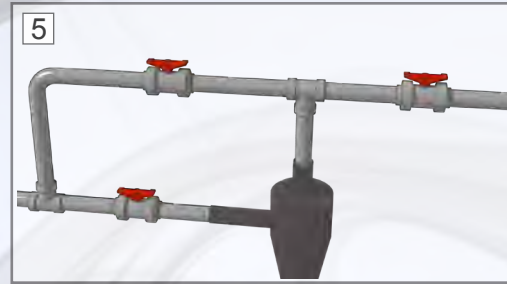
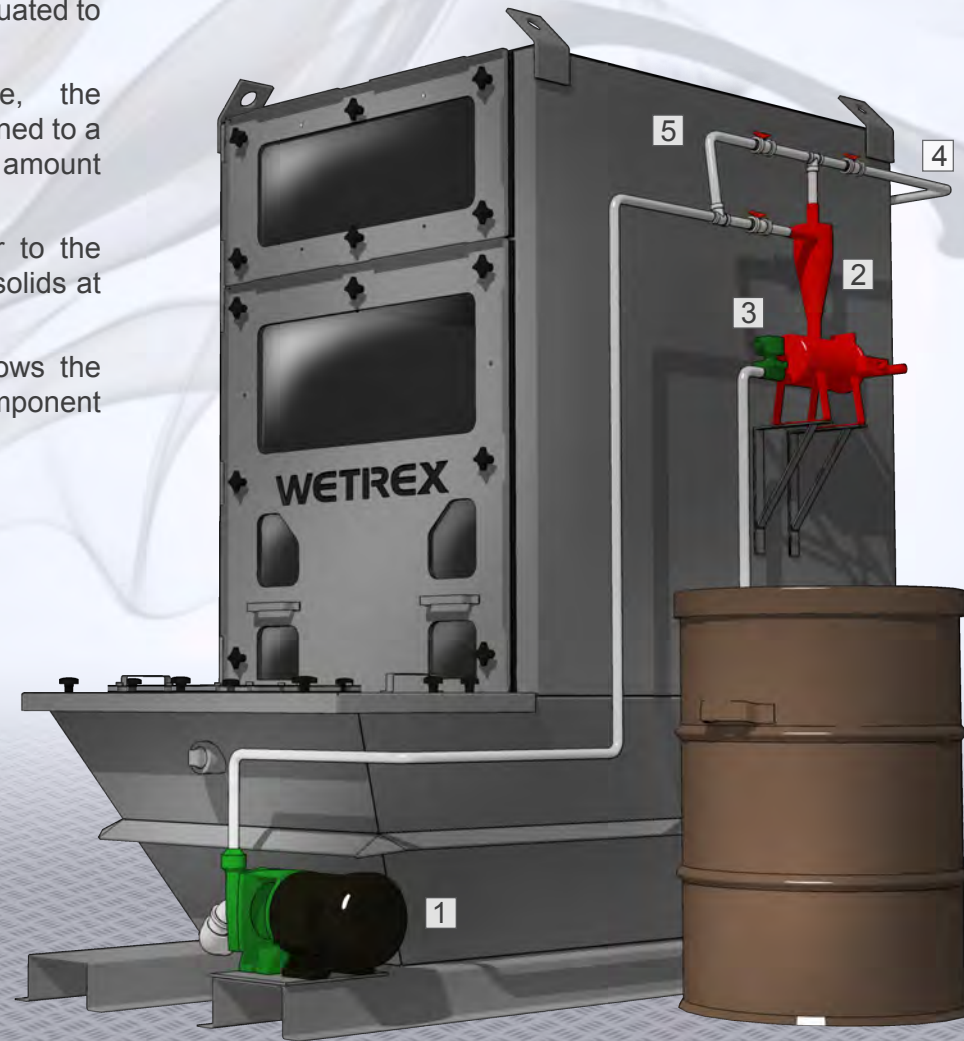
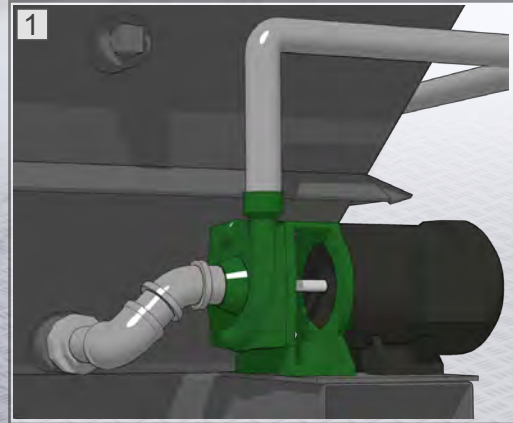

WATER
TREATMENT

7

AVAILABLE WATER FILTRATION SYSTEM CONFIGURATION WHICH BEST SUITS YOUR NEEDS

Option A - manual sludge removal

Designed for applications involving light dust loading, this option is ideal for those looking for a dust collector with low initial cost. Sludge must be removed manually from the basin as there is no filtration system offered. Basin cleaning is made easy thanks to the angled Wetrex™ front access. The cleaning frequency depends on the amount of particles contained in the contaminated air.

Option B - hydrocyclone filtration system

The combination system is designed for moderate to heavy dust loads and applications requiring 24 hour continuous service. With this option, the collected material is pumped either continuously or intermittently through a water filtration system that relies on hydrocyclone technology. Compared to the basic system, this type of system involves less frequent maintenance.

Optimal operating conditions

The majority of particles (50% and more) must be bigger than 40 microns to justify the use of a hydrocyclone.



14 KILLED
36 INJURED

SAFE WORKING
ENVIRONMENT

9

YOUR SAFETY IS OUR PRIORITY

The Wetrex™ is a high tech air filtration system which is best used in highly explosive, reactive dust (aluminum and titanium) and oil mist applications. This unit effectively separates dust particles by saturating the air stream with a water vortex while reducing the potential for an explosion.

This customizable, highly efficient, top quality industrial grade unit requires little maintenance. Its simplicity and high efficiency remain its two greatest advantages.

Our central point ducted wet collector offers high capacity, various volumes and the possibility of using a high pressure duct network, a feature many of our competitors do not have.

AT THE LEFT, SOME TRAGEDIES CAUSED BY DUST EXPLOSION

1. Imperial Sugar Compagny

February 7 2008, Port Wentworth, GA; An unknown source ignited accumulated sugar dust, causing a violent explosion.

2. Hoeganaes Corporation

January 31 2011, Gallatin, TN; fatal flash fire from hydrogen or nitrogen leaking process pipe fueled by combustible iron dust.

3. Hayes Lemmerz International

October 29 2003, Huntington, IN; The company did not identify or control hazards of aluminium dust.

4. West Pharmaceutical Services

January 29 2003, Kingston, NC; accumulated polyethylene dust above the ceiling tiles fueled the explosion.

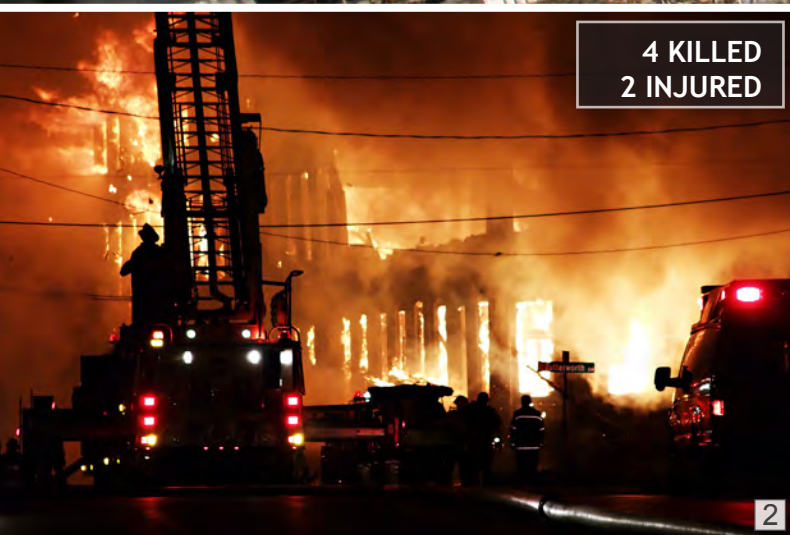

4 KILLED
2 INJURED



1 KILLED
6 INJURED



6 KILLED
38 INJURED

Explosive dust collection waits for a spark in your workplace :

The dangers arising from dust collection are unfortunately not considered enough. Sadly the risk is real and when vigilance is omitted, serious incidents occur.



WET
DOWNDRAFT
TABLE

11

THE WETREX™ SERIES IS AT THE HEART OF MANY OTHER PRODUCTS LIKE THE WDDT™

We have been working diligently to produce a self-contained workstation with an integral water dust collector system.

This unit draws the dust directly into the water filter system, forcing the hazardous particles into a water bath before entering our upright mist elimination chamber and filters.

Our wet downdraft tables meet OSHA and NFPA standards for dust collectors located inside the building.

The series is available with one or two (back-to-back) work tables.

AVAILABLE FEATURES

Transparent sides

The plexiglass workstation enclosure provides containment.

Standard LED lighting

To assist users, all our work tables are equipped with standard light-emitting diodes.

Grates

Different materials are available depending on the application; steel, wood, fiberglass and aluminium.

Added environmental control

The optional regain air system enhances capture velocity by returning a portion of the clean, filtered air through an air curtain located across the top of the booth. This allows the dust to be pushed away from the worker's breathing zone while it simultaneously pulls it into the open table grate.



WET BOOTH

13

THE WETREX™ SERIES IS AT THE HEART OF MANY OTHER PRODUCTS LIKE THE WBX™

We have been working assiduously to produce a new booth for industrial applications.

This self-contained booth incorporates our water dust collector, drawing the dust directly into the water filter system at the back of the booth, forcing the hazardous particles into a water bath before entering our upright mist elimination chamber and filters.

Our booths meet OSHA and NFPA standards for dust collectors located inside the building.

AVAILABLE FEATURES

Lighting

To assist users, all our booths are equipped with fluorescent ballasts. Standard light-emitting diodes can also be an option.

Construction

The series is available in multiple sizes. 16 gauge galvanized steel with acoustical panel siding is standard.

Maintenance

Filters and baffle core are accessible from the inside the booth, which allows for easy maintenance and saves floor space.

Added environmental control

The optional regain air system enhances capture velocity by returning a portion of the clean, filtered air, through an air curtain located across the top of the booth. This allows the dust to be pushed away from the worker's breathing zone while it is simultaneously pushing it across the booth to the rear intakes.

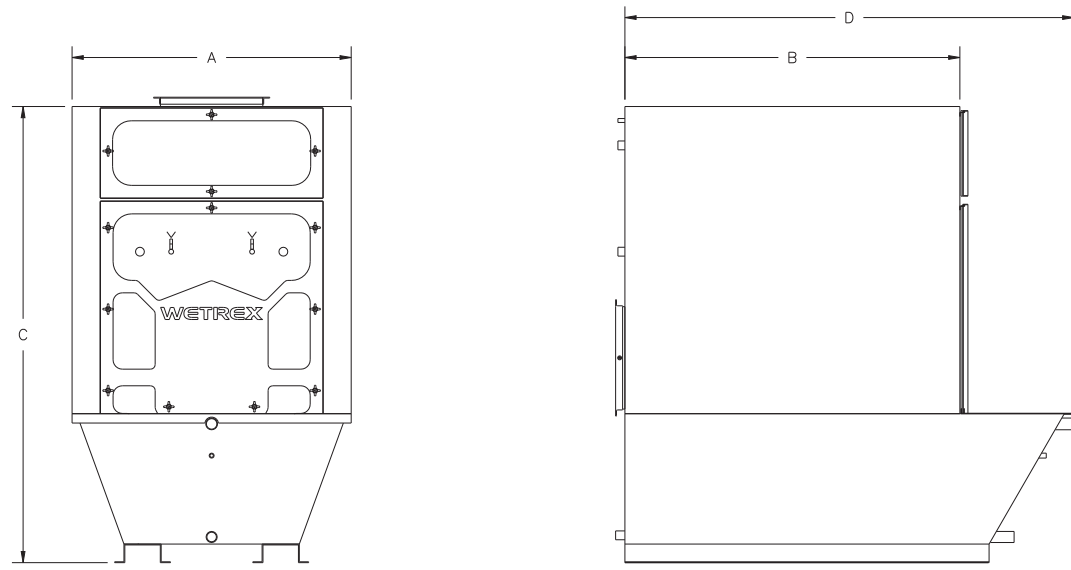

Wetrex™ Model Comparison:

MODEL	AIR CAPACITY (cfm)	A (mm - in)	B (mm - in)	C (mm - in)	D (mm - in)	ENTRY (mm-in)	WATER CAPACITY (liter-gal)	SHIPPING WEIGHT (kg-lbs)	OPERATION WEIGHT (kg-lbs)
Wetrex-01	1000	762 - 30	457 - 18	1702 - 67	990 - 39	254 - 10	246 - 65	567 - 1250	814 - 1795
Wetrex-02	2500	762 - 30	610 - 24	1702 - 67	1143 - 45	254 - 10	284 - 75	680 - 1500	966 - 2130
Wetrex-04	4000	102 - 40	1295 - 51	2007 - 79	1830 - 72	356 - 14	397 - 105	771 - 1700	1170 - 2580
Wetrex-06	6000	1220 - 48	1855 - 73	2210 - 87	2490 - 98	457 - 18	719 - 190	907 - 2000	1628 - 3590
Wetrex-08	8000	1524 - 60	1855 - 73	2490 - 98	2490 - 98	560 - 22	1117 - 295	1247 - 2750	2363 - 5210
Wetrex-10	10000	1524 - 60	1855 - 73	2490 - 98	2490 - 98	560 - 22	1117 - 295	1247 - 2750	2363 - 5210

Wet Downdraft Table Model Comparison:

MODEL	CFM	DIMENSIONS	KW-HP
WDDT-3-1	3000	1 Table - 30'x36'	3.7 - 5
WDDT-3-2	3000	2 Tables - 30'x36'	3.7 - 5
WDDT-3.5-1	4000	1 Table - 30'x48'	3.7 - 5
WDDT-3.5-2	4000	2 Tables - 30'x48'	3.7 - 5
WDDT-4-1	4000	1 Table - 30'x48'	5.6 - 7,5
WDDT-4-2	4000	2 Tables - 30'x48'	5.6 - 7,5
WDDT-6-1	6000	1 Table - 30'x72'	11 - 15
WDDT-6-2	6000	2 Tables - 30'x72'	11 - 15

Wet Booth Model Comparison:

MODEL	CFM	DIMENSIONS	KW-HP
WBX-06	6000	Booth 6' x 8'	1 x 7.4 - 10
WBX-12	12000	Booth 12' x 8'	2 x 7.4 - 10
WBX-18	18000	Booth 18' x 8'	3 x 7.4 - 10
WBX-24	24000	Booth 24' x 8'	4 x 7.4 - 10
WBX-30	30000	Booth 30' x 8'	5 x 7.4 - 10
WBX-36	36000	Booth 36' x 8'	6 x 7.4 - 10
WBX-42	42000	Booth 42' x 8'	7 x 7.4 - 10
WBX-48	48000	Booth 48' x 8'	8 x 7.4 - 10
WBX-54	54000	Booth 54' x 8'	9 x 7.4 - 10
WBX-60	60000	Booth 60' x 8'	10 x 7.4 - 10

STANDARD CHARACTERISTICS	HIGH EFFICIENCY WETREX SERIES	WBX SERIES - WET ENVIRONMENTAL BOOTH	WDDT SERIES - WET DOWNDRAFT TABLE
12 gauge construction	X		
16 gauge construction		X	X
Standard magnehelic gauge	X	X	X
Led / light kit		X	X
Front access core baffle	X	X	X
Steel grates			X
Transparent side windows			X
Removable inspection doors	X	X	X
Ultrasonic water level sensor	X	X	X
Water level control panel (prewired)	X	X	X
Electronic water level display	X	X	X
On / off magnetic motor starter & thermal overload panel	X	X	X
Direct drive non overloading blowers	X	X	X
Easy sloped clean out	X	X	X
Manual cleaning trap	X	X	X
Drain	X	X	X
Lifting lugs	X	X	X
High efficiency mist eliminator	X	X	X

OPTIONAL FEATURES	HIGH EFFICIENCY WETREX SERIES	WBX SERIES - WET ENVIRONMENTAL BOOTH	WDDT SERIES - WET DOWNDRAFT TABLE
Stainless steel construction	X	X	X
Custom paint	X	X	X
Fiberglass grates			X
Aluminum grates			X
Wood grates			X
High / low level alarm	X	X	X
Explosion proof motor	X	X	X
HEPA Secondary filters	X	X	X
Spray wash system	X	X	X
Power vent or barometric damper	X	X	X
Sound insulation		X	
Class 1, Div. 2 lighting & controls		X	X
Regain air curtain and damper		X	X
Crane slot		X	X
Hydrocyclone sludge removal system	X	X	X



Stainless steel unit for spices with a fast acting ball valve for water flush
Food processing



Dry powder stations - batch dumping
Explosive powders



Aluminum buffing/grinding - ducted system
Aerospace



Aluminum grinding - double table with regain system
Aerospace



Head Office

10801 Electron Drive
Louisville, KY 40299

Tel. : 502.267.0333
Toll Free : 1-800.264.8958
Fax : 502.267.4241

info@diversair.com
www.diversair.com