

DIVERSIFIED AIR SYSTEMS, INC.

MAXFLO D-70™ series

Industrial Air Cleaners

- *Economical way to improve air quality 65% to 85%*
- *Helps meet or exceed OSHA standards*
- *Recirculates clean air, eliminating the need for expensive make-up air*

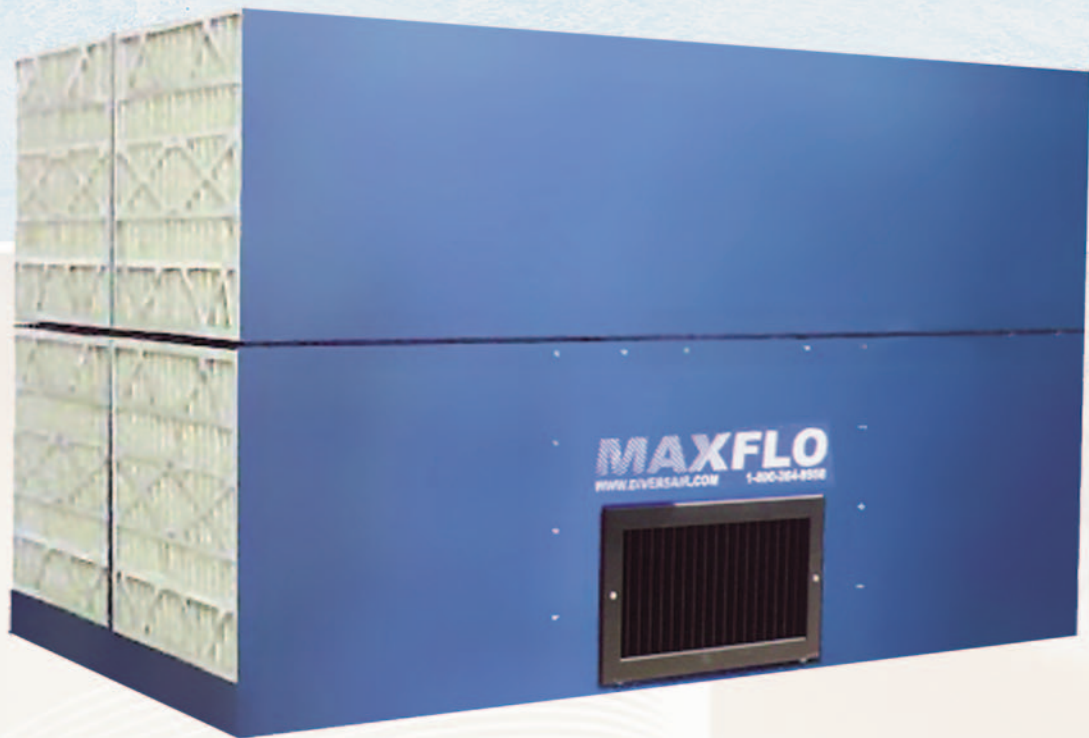

- *Reduces housekeeping costs and improves productivity*
- *Minimal installation required, ceiling or side wall mounted*
- *Ships fully assembled, 7000 to 7600 CFM range*

Superior technology generating substantial operating savings

TYPICAL APPLICATIONS FOR THE MAXFLO AMBIENT AIR CLEANERS

- Welding Smoke • Grinding Dust • Sanding Dust • Oil Smoke • Coolant Mist • Powders • Odors, etc...

OUTSTANDING MAXFLO D SERIES FEATURES

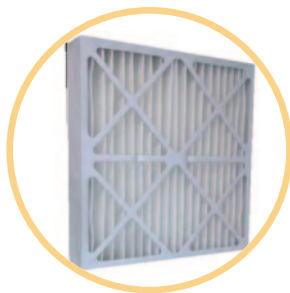
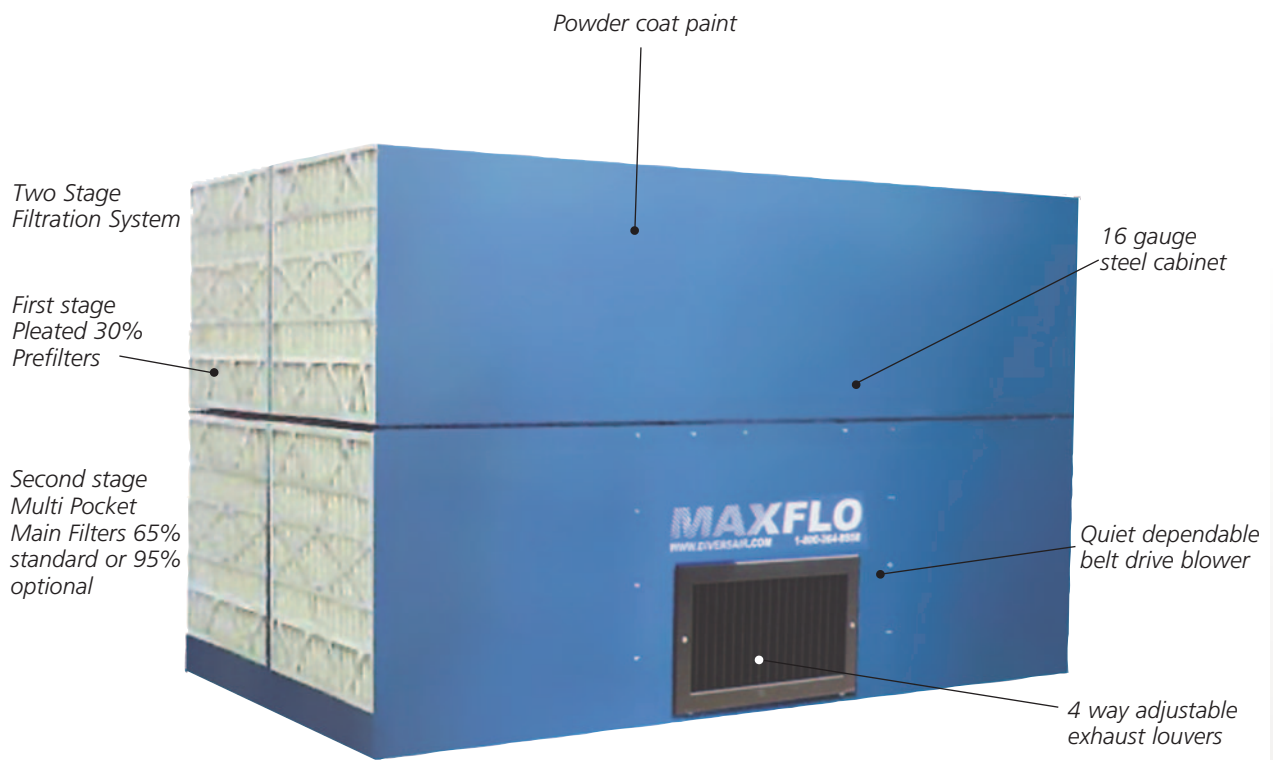

First stage Pleated Prefilters

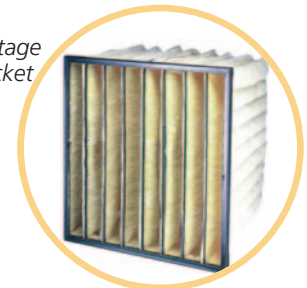

Second stage Multi Pocket bag filter

Made in USA
3 YEAR WARRANTY

Ideal for automotive industry, welding shops, vocational schools, training facilities, laboratories, wood working shops, metal transforming industries, batching and powder processes.

Call today: 800-264-8958

MAXFLO D-70 SERIES SPECIFICATIONS

16 GAUGE STEEL CABINET FINISHED WITH A DARK BLUE CHEMICAL RESISTANT POLYURETHANE PAINT, FOUR WAY INDIVIDUALLY ADJUSTABLE BLADES, AND A SINGLE SPEED, BELT DRIVEN MOTOR WIRED TO JUNCTION BOX ON UNIT.

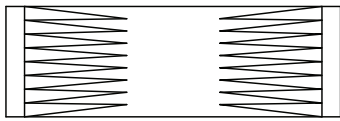

TOP VIEW

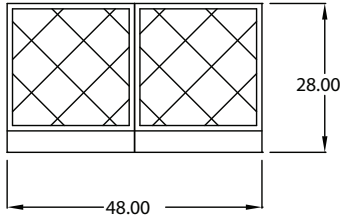

SIDE VIEW

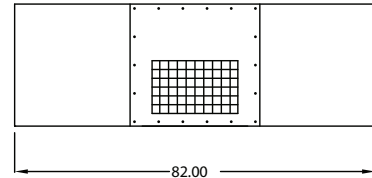

FRONT VIEW

| SPECIFICATIONS | | | |
|----------------|--|----------|---|
| AIRFLOW: | D-70 | 7000 CFM | PREFILTERS: (Depends on config.) (4) 4" Pleated Std. (4) Aluminum Mesh, Opt. |
| | D-75 | 7500 CFM | |
| | D-76 | 7600 CFM | |
| ELECTRICAL: | 5 HP 208-230/460/3, 14.0-13.0/6.5 Amps | | MAIN FILTERS: (Depends on config.) (4) 22" 8 pocket 65%, Std. (4) 22" 8 pocket 95%, Opt. |
| WARRANTY: | 3 Years on all parts except filters | | NOISE: 82 dBA |
| OPTIONS: | Filter replacement gauge, Mounting bracket, Silencer | | |

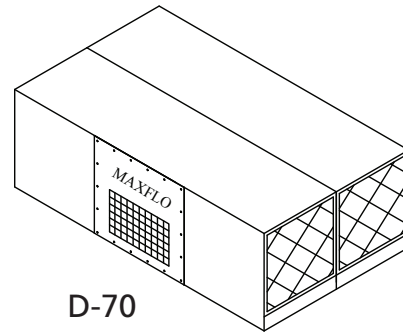

D-70

MAXFLO D-70 SERIES OPTIONAL MULTIPLE CABINET CONFIGURATION

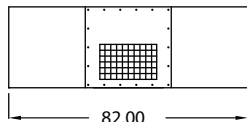

FRONT VIEW

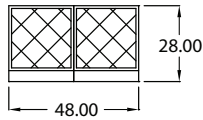

SIDE VIEW

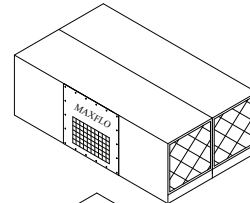

D-70

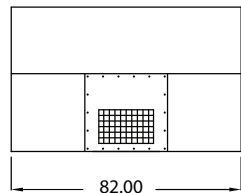

FRONT VIEW

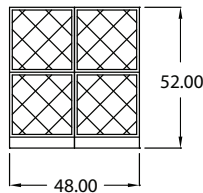

SIDE VIEW

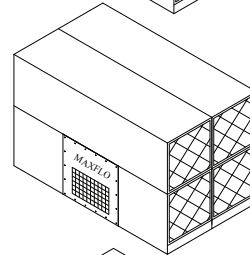

D-75

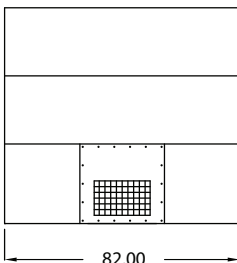

FRONT VIEW

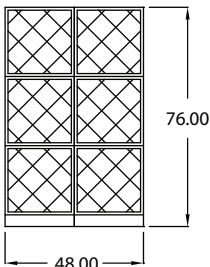

SIDE VIEW

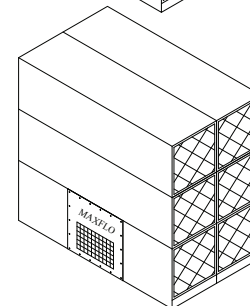

D-76

Call today: 800-264-8958

FREE HANGING UNDUCTED AIR CLEANING SYSTEMS

Unducted air cleaning systems consist of one or more interior air cleaners positioned in the overhead plant space to create a planned air circulation airflow pattern. This method effectively cleans the overall ambient air. Unducted systems rely on constant cleaning and mixing of the entire area volume to remove contaminants. Unducted systems never remove 100% of the contaminants. The objective of this method is to achieve a substantial contaminant reduction at steady-state levels. Unducted systems will typically provide an estimated 65 to 85% contaminant reduction. The percentage reduction is based on the number of air changes provided by the unducted air cleaning system.

Recommended Air Flow Patterns

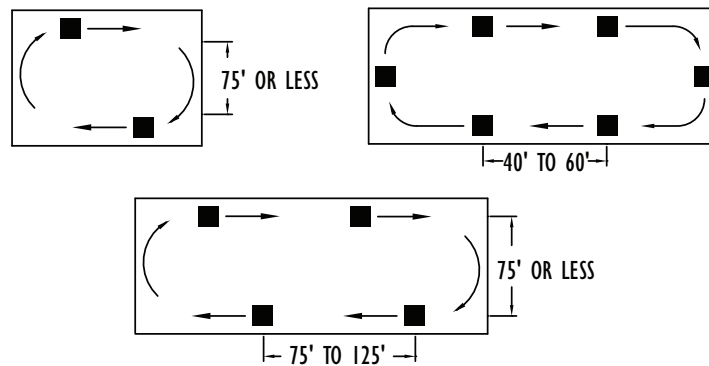

CIRCULAR AIR PATTERNS

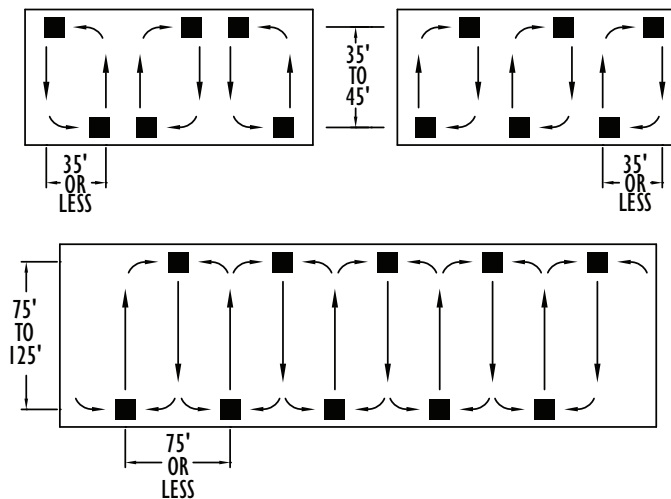

CROSS-BAY PATTERNS