

DIVERSIFIED AIR SYSTEMS, INC.

MAXFLO™-PHV-II

Portable High Vacuum System

- ***Powerful 3.9 HP motor, 120/1/60, Nominal 245 CFM***
- ***Applications: Welding, Sanding, Grinding, & Housekeeping***
- ***Cyclonic prefiltration with secondary cartridge filtration***



- ***Motor housing is insulated & baffled for quiet operation***
- ***Heavy duty 14 gauge construction, powder coated paint***
- ***Optional final 99.97% HEPA filtration***

Superior technology generating substantial operating savings

OUTSTANDING MAXFLO STANDARD FEATURES

You don't have to work in a dirty environment! Install a MAXFLO-PHV Portable High Vacuum System, and its powerful turbine pump and cyclone will remove virtually all dust and fumes at the source. Improves air quality, production, quality control, reduces housekeeping and energy costs.

SPECIFICATIONS

- 3.9 HP Motor, 120/1/60, 15.5 amps, on/off switch, 15' power cord
- Cartridge filter, 43 sq. ft.
- Dust container, 204 sq. ft.
- Weight 100 lbs.

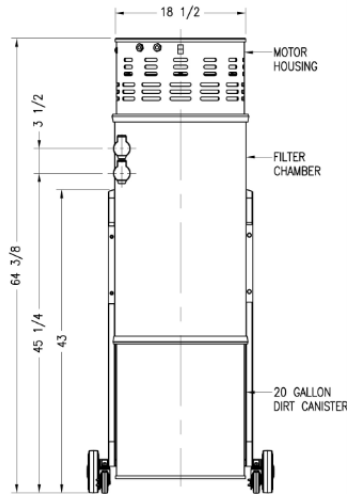
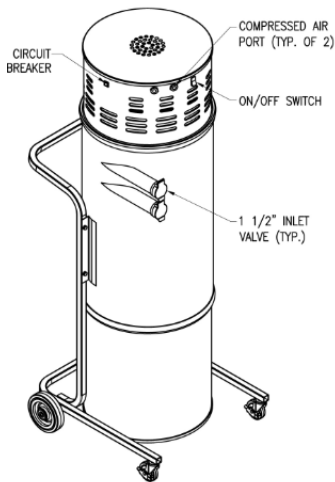
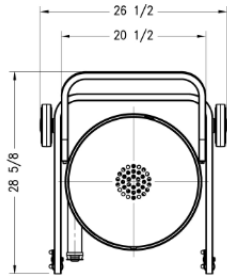

FEATURES

- Powerful 3.9 HP, 1753 watt pump with 2 vacuum inlets. Produces nominal 70" of water column; 245 free flow CFM.
- Quiet operation...motor housing is insulated and baffled for sound.
- Superior filtration...combination true cyclonic filtration plus secondary cartridge filter. Unlike most portables utilizing a cartridge filter, a standpipe surrounding the cartridge filter does not allow the dust laden air entering the inlets to go directly to the cartridge filter. The standpipe forces the air to move down the canister to the cyclone where 85% of the sanding dust is removed before the secondary cartridge filter. This results in the unit operating much more efficiently than units which do not have true cyclonic filtration.
- HEPA filtration is available by adding a chamber between the pump and regular filters. HEPA filter removes the remaining 99.97% of sanding dust to a minimum of .3 micron particle.
- Heavy duty construction of 14 gauge steel with a tough powder coat finish.

OPTIONAL FEATURES

- On/off feature...motor is turned on and off automatically by air switches when pneumatic tools are activated. This increases the life of the motor and reduces energy costs of running the motor.
- Welding fume extraction guns and hoods
- High vacuum grinding & sanding tools
- Housekeeping tools
- Anti-static vacuum hose

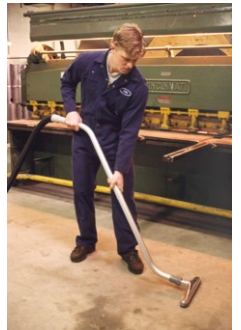
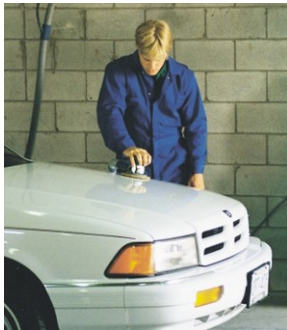

Note: Specifications listed above may be modified to suit application. contact D.A.S. or representative for information.

Diversified Air Systems, Inc.

10801 Electron Drive, Louisville, Kentucky 40299

Toll free: **(800) 264-8958**

Tel.: **(502) 267-0333** • Fax: **(502) 267-4241**

Website: www.diversair.com • email: info@diversair.com