

DIVERSIFIED AIR SYSTEMS, INC.

MAXFLO™-PAC

Portable Air Cleaner

- *Collects dust, fumes, mist, smoke, and odors*
- *Plug and play unit, total self-contained with MAXFLO fume arm, 1.5 HP Motor with direct drive blower wheel, 120/1/60, low noise level*
- *Nominal 1800 CFM with 8" x 10' MAXFLO Fume Arm
Nominal 1200 CFM with 6" x 10' MAXFLO Fume Arm*



- *Recirculates clean air, which eliminates the need for expensive exhaust*
- *Flexible filter combinations, easy to use & maintain*
- *Standard 95% @ 1 micron high efficiency media filter with optional 99.97 HEPA and refillable adsorption module*

Superior technology generating substantial operating savings

MAXFLO PORTABLE AIR CLEANER

Diversified Air Systems, Inc. now offers an easy to use portable air cleaner. The MAXFLO-PAC is a totally self-contained portable filtration unit. Standard filtration consist of aluminum mesh pre-filter followed by a MERV 14 (95% at 1 micron) metal box filter. Separate access door allows for easy access to filters. Direct drive blower wheel. On/off switch with 8' power cord. Just roll the unit to your job, plug it in and turn it on. Captures fumes at the source with a Maxflo source capture fume arm.

OUTSTANDING STANDARD MAXFLO PORTABLE AIR CLEANER FEATURES



TYPICAL APPLICATIONS FOR THE MAXFLO PAC PORTABLE AIR CLEANER

• WELDING • GRINDING • SANDING • DUST • POWDERS • MIST & SMOKE, ETC.

Made in USA
1 YEAR LIMITED WARRANTY

CALL TODAY : 800-264-8958

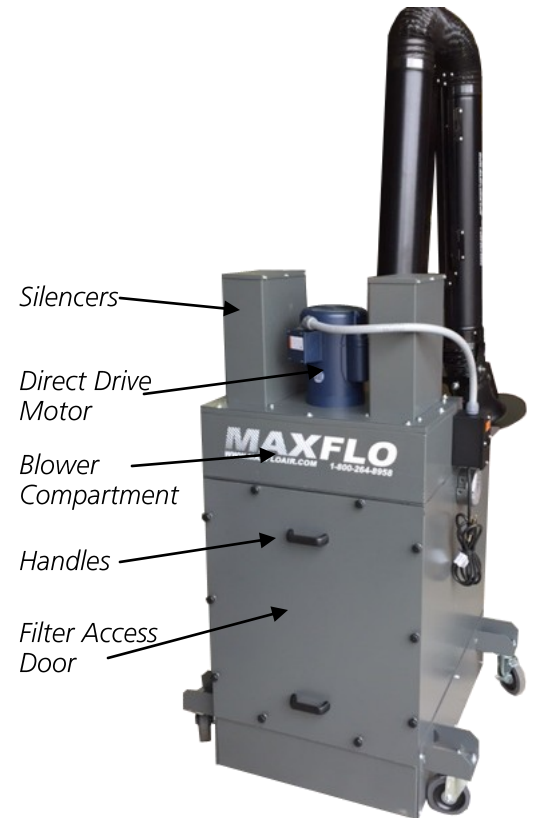
OUTSTANDING MAXFLO PAC SERIES FEATURES**SPECIFICATIONS**

Dimensions: 38" W x 34" D x 60" H
 Fume Arm: Standard 6" Diameter x 10' Length
 Fume Arm Base from Floor: 38"
 Electrical: 1.5 HP Motor, 120/1/60
 Direct Drive Motor Non-Sparking Blower Wheel
 Motor Mounted Out of Airstream
 Airflow: Nominal 1200 CFM w/ 6"x10' Fume Arm
 1800 CFM w/ 8"x10' Fume Arm
 Weight: 500 lbs.
 Noise: 73 DBA Nominal
 Construction: 14 Gauge Cabinet
 Color: Powder Coated Gray

OPTIONAL FEATURES

- 3 Phase Motor
- Light in Hood
- Exhaust Dampers
- Variable Frequency Drives
- Fume Arm Diameters: 4", 5", 6" & 8"
- Dual Arms
- Fume Arm Lengths: 7', 10', & 14'
- HEPA Filtration
- Absorption Modules

MAXFLO-PAC STANDARD FILTER ARRANGEMENT

- (1) - 1" Aluminum Mesh
- (1) - 95% @ 1 Micron (MERV 14) Fiberglass Box Filter, 58 sq. ft.
- (1) 2" Aluminum Mesh After Filter

Note: Specifications listed above may be modified to suit application. contact D.A.S. or representative for information.

Diversified Air Systems, Inc.

10801 Electron Drive, Louisville, Kentucky 40299

Toll free: **(800) 264-8958**

Tel.: **(502) 267-0333** • Fax: **(502) 267-4241**

Website: www.diversair.com • email: info@diversair.com