

DIVERSIFIED AIR SYSTEMS, INC.

# MAXFLO-SC™

*Stand alone pleated single cartridge  
dust collector*

- *Plug and play type unit*
- *High efficiency cartridge*
- *Ideal for welding, light grinding and  
general dust applications*



- *Pulse cleaning system*
- *Ships fully assembled*
- *Powerful and ultra quiet 1.5 HP spark proof fan*

*Superior technology generating substantial operating savings*

# MAXFLO-SC™

*Stand alone dust collector*

## **MAXFLO-SC** *Stand alone high efficiency single cartridge collector*

MAXFLO-SC single cartridge collectors are designed for a wide range of particle filtration. Using the same technology as the regular and larger MAXFLO-CC collector, this unit is perfectly designed for individual work stations by not needing extensive installation or major duct work requirements. Shipped fully assembled and taking very little footprint, the unit can be in service rapidly. The quiet motor-fan assembly with anti-spark polyamide backward inclined impeller allows great air volume and medium to high static pressures. The integrated control panel ensures constant and reliable cleaning of the cartridges by manual air pulse. Efficiency of cartridge may allow recirculation of filtered air into the premises (some restrictions apply).

Filtration of reactive material is allowed since the interior volume of the unit is less than 0.8 cubic feet. Maintenance is a snap by only emptying the dust storage bin.

## *Industrial Air Specialists*

With our headquarters in Louisville, Kentucky, Diversified Air Systems, Inc. has been providing quality air solutions to industrial and commercial facilities since 1981. During our more than thirty years of operation, Diversified Air Systems, Inc. has established two important company traditions: offering state-of-the-art equipment at competitive prices and achieving long-term customer satisfaction.

The staff of Diversified Air Systems, Inc. includes five application engineers, with a combined experience of more than 75 years in the air filtration and HVAC industry. Whether your facility requires an air filtration system for dust, mist, or fumes, or an HVAC solution to meet ventilation needs, Diversified Air Systems, Inc. has the equipment and expertise to meet the need.



Services include air quality analysis, system design, equipment sales, turnkey installation, onsite servicing, and supply of replacement filters and accessories.

### **Other filtration systems available:**

Air Cleaners  
Containment Booths  
Decontamination Booths  
Downdraft Tables  
Dust Collectors  
Fans and Blowers  
Gas & Odor Control

High Vacuum Systems  
Mist Collectors  
Portable Paint / Fume Booths  
Sparks suppression  
Stainless Steel Collectors  
Vehicle Exhaust Systems  
Wet Dust Collectors

**Call today: 800-264-8958**

## MAXFLO-SC DOWNFLOW HORIZONTAL CARTRIDGE COLLECTORS

- Ideal for welding fumes and fine grinding dusts
- Self cleaning with reverse air pulse
- Minimal footprint
- Compact dust storage bin
- Robust painted steel cabinet
- Plug and play type unit

## OUTSTANDING MAXFLO-SC FEATURES

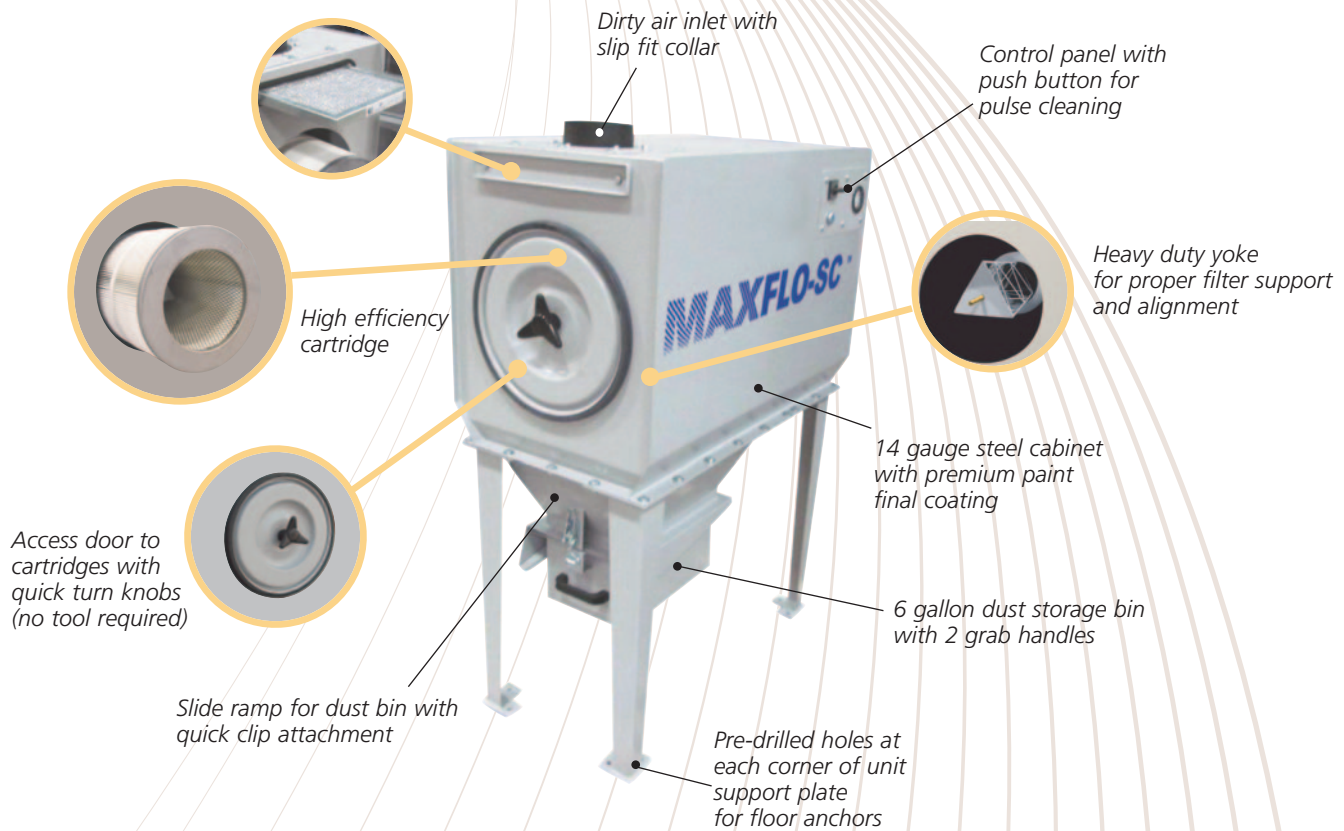

## GENERAL INFORMATION

CHART 1

MODEL	# OF CARTRIDGES	FILTRATION SURFACE SQ.FT. / SQ.MT	MAX. AIR VOLUME CFM / LS	MAX. HP / KW	MOTOR RPM	WEIGHT LB / KG	AIR PRESSURE REQUIRED (PULSE CLEANING)
1DPF-C01	1	260 / 24	800 / 375 (6'w.g.)	1.50 / 1.10	3000	380 / 172	60-80 PSI

Motor voltages note: standard voltage is 115/1/60. Optional 230/1/60 or 230/460/1/60. Contact factory for details.

### Cartridge efficiency:

130 sq. ft. polyester: U.S. & G 99.93 @ 0.2/2.0 microns

130 sq. ft. polyester anti-static: U.S. & G 99.93 @ 0.2/2.0 microns

260 sq. ft. regular cellulose: U.S. & G 99.5 @ 0.2/2.0 microns

260 sq. ft. nanofiber: MERV 15 as ASHRAE 52.2

260 sq. ft. fire retardant: U.S. & G 99.5 or MERV 15

Note: installation must be made according to local building codes and regulations.

**Call today: 800-264-8958**

## DIMENSIONS

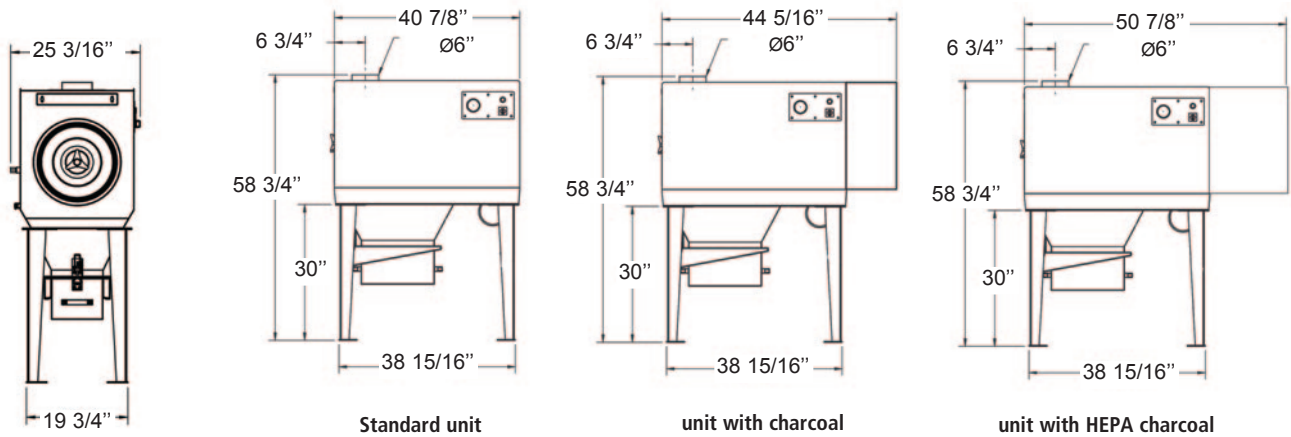

## CREATE YOUR MAXFLO-SC FILTRATION UNIT SPECIFICATION

### 1. UNIT SHOULD INCLUDE:

14 gauge polyurethane painted with aluminum primer steel cabinet, high efficiency cellulose cartridge, 260 sq. ft., access doors to cartridges, heavy duty support yokes for cartridge, venturi for proper cartridge pulse cleaning, aluminum pre-filter above first cartridge, access door to cartridge, dust hopper and 6 gallon dust storage bin with two (2) grab handles, slide ramp and quick clip attachment from hopper to dust bin, control panel with ON/OFF switch (for 115V only) and manual push button for pulse cleaning, TEFC 1.5 HP motor, direct drive 3000 RPM, AMCA type B spark proof impeller, 3/8" NPT compressed air connection, 6" top slip fit inlet and rear air outlet, painted steel support structure with pre-drilled holes for floor anchoring,

### 2. VOLTAGE TO BE:

115/1/60  230/1/60  230/460/1/60

### 3. STANDARD CELLULOSE CARTRIDGES TO BE SUBSTITUTED FOR:

- A) Fire retardant cellulose cartridges (260 sq. ft. each)
- B) Nanofiber cartridges (260 sq. ft. each)

C) Polyester cartridges (130 sq. ft. each)

D) Anti-static polyester cartridges (130 sq. ft. each)

### 4. UNIT TO BE EQUIPPED WITH:

- A) Magnehelic pressure gauge
- B) Sprinkler head
- C) Charcoal after-filter
- D) HEPA after-filter
- E) Pulse cleaning with timer sequence
- F) 6" Maxflo fume arm
- G) 15 gallon dust bin

### 5. REPLACEMENT/SPARE PARTS:

- A) Aluminum pre-filter
- B) Main cartridge
- C) Charcoal after-filter
- D) HEPA after-filter

Note : specifications listed above may be modified to suit application. Contact D.A.S. or representative for information.

### Diversified Air Systems, Inc.

10801 Electron Drive, Louisville, Kentucky 40299

Toll free: **(800) 264-8958**

Tel.: **(502) 267-0333** • Fax: **(502) 267-4241**

Website: [www.diversair.com](http://www.diversair.com) • email: [info@diversair.com](mailto:info@diversair.com)