

DIVERSIFIED AIR SYSTEMS, INC.

MAXFLO-DD™

downdraft table

- *250 FPM downdraft velocity*
- *Helps meet or exceed OSHA standards*
- *Recirculates clean air, eliminating the need for expensive make-up air*



- *Cartridge filtration with reverse jet pulse cleaning system*
- *Quiet operation, low air to cloth ratio*
- *Ships fully assembled, plug & play ready to use*

Superior technology generating substantial operating savings

MAXFLO-DD™

High-Productivity Innovative Products

MAXFLO-DD *Downdraft table*

Downdraft filtering work benches are an effective method to remove harmful pollutants away from the worker's breathing zone. The bar grate work surface allows dusts and particles to be drawn in a down flow pattern toward the highly efficient filtering system. The quiet and powerful motor fan assembly ensures contaminants will not be released into the plant ambient air. Applications vary from buffing, sanding, fume control and many other industrial processes. High efficiency filters allow clean air to be recycled within the facility translating into major energy savings.

Industrial Air Specialists

With our headquarters in Louisville, Kentucky, Diversified Air Systems, Inc. has been providing quality air solutions to industrial and commercial facilities since 1981. During our more than thirty years of operation, Diversified Air Systems, Inc. has established two important company traditions: offering state-of-the-art equipment at competitive prices and achieving long-term customer satisfaction.

The staff of Diversified Air Systems, Inc. includes five application engineers, with a combined experience of more than 75 years in the air filtration and HVAC industry. Whether your facility requires an air filtration system for dust, mist, or fumes, or an HVAC solution to meet ventilation needs, Diversified Air Systems, Inc. has the equipment and expertise to meet the need.



Services include air quality analysis, system design, equipment sales, turnkey installation, onsite servicing, and supply of replacement filters and accessories.

Other filtration systems available:

Air Cleaners
Containment Booths
Decontamination Booths
Downdraft Tables
Dust Collectors
Fans and Blowers
Gas & Odor Control

High Vacuum Systems
Mist Collectors
Portable Paint / Fume Booths
Sparks suppression
Stainless Steel Collectors
Vehicle Exhaust Systems
Wet Dust Collectors

TYPICAL APPLICATIONS FOR THE MAXFLO-DD DOWNDRAFT TABLE

- Welding • Buffing • Deburring • Cutting • Grinding • Mixing • Sanding

OUTSTANDING MAXFLO-DD FEATURES



**Made in USA
2 YEAR WARRANTY**

Call today: 800-264-8958

OUTSTANDING MAXFLO-DD FEATURES



Filter access door



Cartridge filter access door opened showing filter locking handle



External dust pan opened



Steel bar grate



Magnetic starter with auto pulse controls

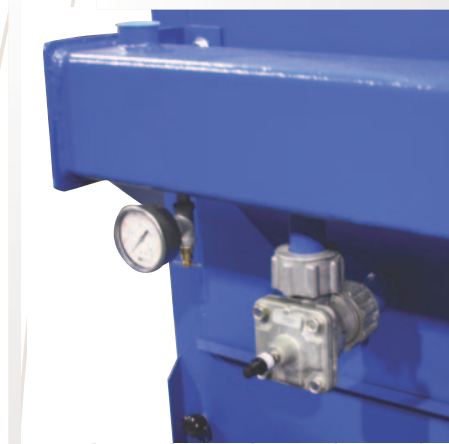

Manual pulse button and air pressure gauge

OUTSTANDING MAXFLO FEATURES



Dual backdraft table



Single backdraft table



DD-22 with optional fume arm

OPTIONS

- Side shields and top panel
- Aluminum or fiberglass bar grating
- Automatic pulse cleaning systems
- 3 inch castor wheels
- HEPA after filter module
- Metal mesh prefilters
- Magnehelic pressure gauge
- Fume arm (DD-22 only)
- Silencer
- Dust tight fluorescent light
- Custom sizes
- Spun bond polyester media

Call today: 800-264-8958

OUTSTANDING MAXFLO-DD FEATURES

HEAVY DUTY 14 GAUGE STEEL CABINET FINISHED WITH A DARK BLUE CHEMICAL RESISTANT POLYURETHANE PAINT, MANUALLY ACTIVATED REVERSE JET PULSE, 24" X 21" TABLE AREA WITH STEEL FLAT BAR GRATE, AND A BUILT IN MOTOR/BLOWER SYSTEM WITH A 200 FPM DOWNDRAFT VELOCITY.

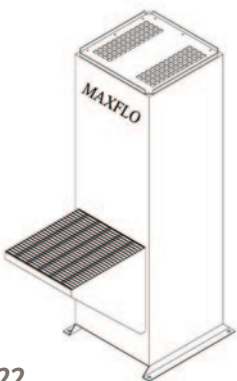

DD-22



TOP VIEW

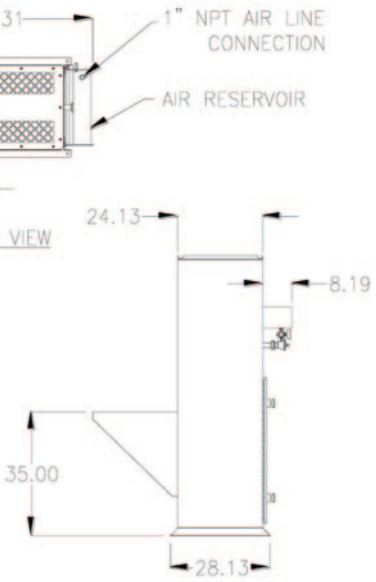

FRONT VIEW

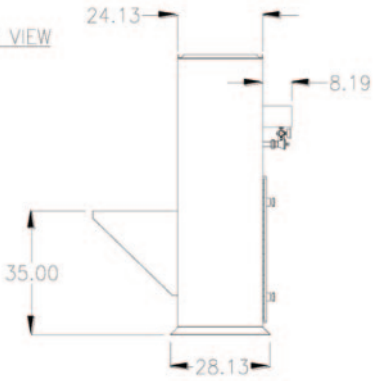

SIDE VIEW

| SPECIFICATIONS | | | |
|----------------|--|---------------|--|
| AIRFLOW: | 750 CFM @ 5" w.g. (1.5 HP, Std.) 1500 CFM @ 5" w.g. (3 HP, Opt.) | PREFILTERS: | (1) Metal Mesh, Std. |
| ELECTRICAL: | 1.5 HP 115/230/460/3/60, Std. 3 HP 115/230/460/3/60, Opt. | MAIN FILTERS: | (1) 80/20 Cellulose Polyester Cartridge, Std. (1) Washable Spunbond, Opt. |
| WARRANTY: | 2 Years on all parts except filters | AFTERFILTERS: | (1) 12" 99.97 HEPA, Opt. |
| OPTIONS: | Automatic pulse cleaning system silencer, side shields, portable castor wheels, w/outriggers, Magnehelic gauge, Magnehelic motor starter | | |

HEAVY DUTY 11 AND 14 GAUGE STEEL CABINET FINISHED WITH A DARK BLUE CHEMICAL RESISTANT POLYURETHANE PAINT, MANUALLY ACTIVATED REVERSE JET PULSE, 2" X 3" TABLE AREA WITH STEEL FLAT BAR GRATE, AND A BUILT IN MOTOR/BLOWER SYSTEM WITH A 250 FPM DOWNDRAFT VELOCITY.

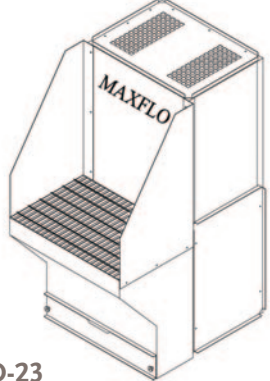

DD-23

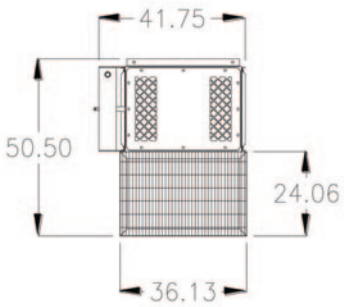

TOP VIEW

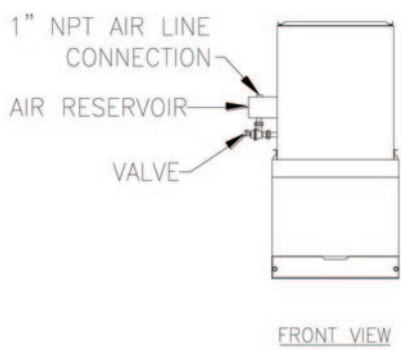

FRONT VIEW

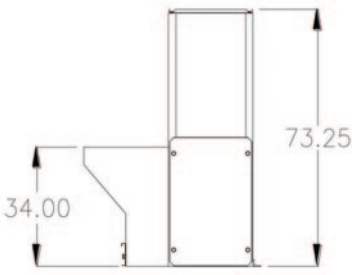

SIDE VIEW

| SPECIFICATIONS | | | |
|----------------|--|---------------|---|
| AIRFLOW: | 1500 CFM @ 3" w.g. | PREFILTERS: | (2) Baffle filters, Std. (2) Metal Mesh, Opt. |
| ELECTRICAL: | 2 HP 115/230/460/3/60, Std. | MAIN FILTERS: | (2) 30" 80/20 Cellulose Polyester Std. (2) Washable Spunbond, Opt. |
| WARRANTY: | 2 Years on all parts except filters | AFTERFILTERS: | (1) 12" 99.97 HEPA, Opt. |
| OPTIONS: | Automatic pulse cleaning system, dust-Tite lights, side shields, 3" castor wheels, Magnetic gauge, aluminum grating, fiberglass grating. | | |

HEAVY DUTY 11 AND 14 GAUGE STEEL CABINET FINISHED WITH A DARK BLUE CHEMICAL RESISTANT POLYURETHANE PAINT, MANUALLY ACTIVATED REVERSE JET PULSE, 3" X 4" TABLE AREA WITH STEEL FLAT BAR GRATE, AND A BUILT IN MOTOR/BLOWER SYSTEM WITH A 250 FPM DOWNDRAFT VELOCITY.

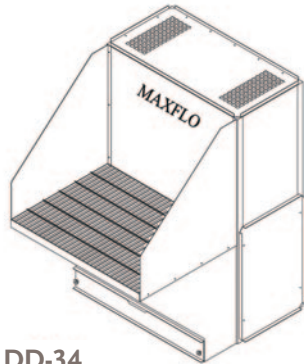

DD-34

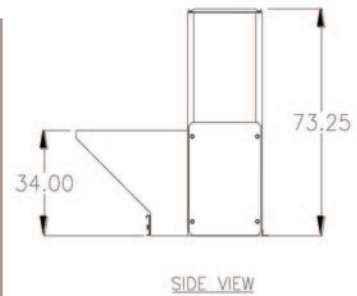
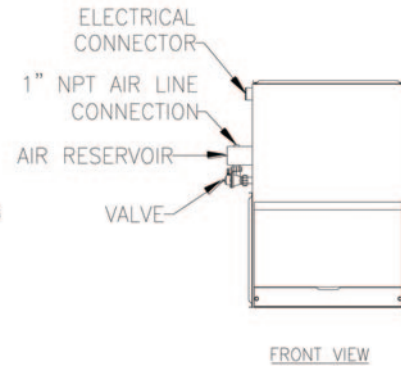
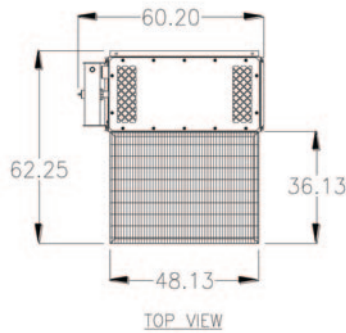

SPECIFICATIONS

| | | | |
|-------------|--|---------------|---|
| AIRFLOW: | 3000 CFM @ 3" w.g. | PREFILTERS: | (2) Baffle filters, Std. (3) Metal Mesh, Opt. |
| ELECTRICAL: | 5 HP 230/460/3/60, Std. | MAIN FILTERS: | (3) 30" 80/20 Cellulose Polyester Std. (3) Washable Spunbond, Opt. |
| WARRANTY: | 2 Years on all parts except filters | AFTERFILTERS: | (2) 12" 99.97 HEPA, Opt. |
| OPTIONS: | Automatic pulse cleaning system, dust-Tite lights, side shields, 3" castor wheels, Magnetic gauge, aluminum grating, fiberglass grating. | | |

HEAVY DUTY 11 AND 14 GAUGE STEEL CABINET FINISHED WITH A DARK BLUE CHEMICAL RESISTANT POLYURETHANE PAINT, MANUALLY ACTIVATED REVERSE JET PULSE, 3" X 6" TABLE AREA WITH STEEL FLAT BAR GRATE, AND A BUILT IN MOTOR/BLOWER SYSTEM WITH A 250 FPM DOWNDRAFT VELOCITY.

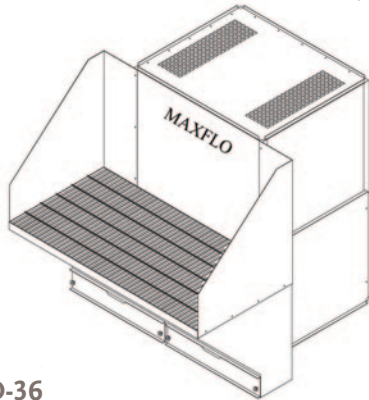

DD-36

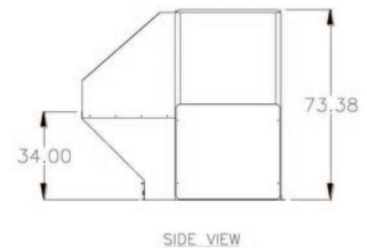
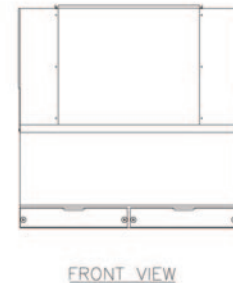
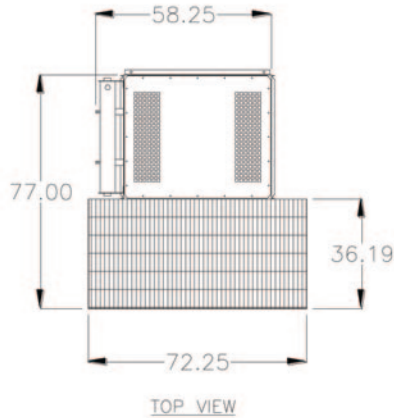

SPECIFICATIONS

| | | | |
|-------------|---|---------------|---|
| AIRFLOW: | 4500 CFM @ 3" w.g. | PREFILTERS: | (2) Baffle filters, Std. (4) Metal Mesh, Opt. |
| ELECTRICAL: | 7.5 HP 230/460/3/60, Std. | MAIN FILTERS: | (6) 30" 80/20 Cellulose Polyester Std. (6) Washable Spunbond, Opt. |
| WARRANTY: | 2 Years on all parts except filters | AFTERFILTERS: | (2) 12" 99.97 HEPA, Opt. |
| OPTIONS: | Automatic pulse cleaning system, dust-Tite light, side shields, 4" castor wheels, Magnetic gauge, aluminum grating, fiberglass grating. | | |

MAXFLO DUST COLLECTORS



MAXFLO-HC™
Safe, high-performance, modular down flow collector with cartridges.

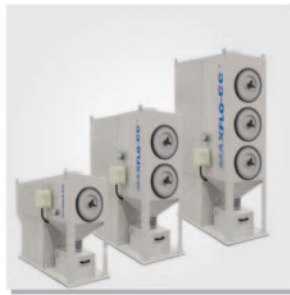

MAXFLO-CC™
Upright pulse cleaning dust collectors, up to 2200 CFM capacity.



MAXPLY™
Manual shaker-type dust collector with bags for light to medium duty applications.



MAXVIBE™
Motorized shaker-type dust collector with bags for light to medium duty applications.

MAXFLO CAPTURE EQUIPMENT



MAXFLO™
Articulated fume extractor arm



MINICART™ MAXROLL™
Compact and portable air filtration units
MAXCART™ High-capacity portable filtration unit



MAXRAIL™
Ceiling or wall-mounted exhaust rail ducting system with trolley



MAXBOOM™
MAXREACH-BD™
Extension pivot boom (single or double)



MAXREEL™
Hose reel (spring recoil or motorized) for fume exhaust



MAXTOP™
Ceiling mounted air filtration unit (1, 2 or 3 arm configuration)



MAXFLO WET COLLECTORS
Downdraft, booths and direct capture models



MAXDRIVE™
Wide range of high-performance industrial fans

Note : specifications listed above may be modified to suit application. Contact D.A.S. or representative for information.

Diversified Air Systems, Inc.

10801 Electron Drive, Louisville, Kentucky 40299

Toll free: **(800) 264-8958**

Tel.: **(502) 267-0333** • Fax: **(502) 267-4241**

Website: www.diversair.com • email: info@diversair.com